

过滤器 /Filter

型号注释 /Note for type:

UF	—	02	D
↓		↓	↓
系列代码: Series Code:		接管口径: Joint Pipe Bore:	排水方式: Drain Type:
F、UF 系列过滤器 F、UF Series Filter		02:G1/4" 03:G 3/8" 04:G1/2" 06:G3/4" 08:G1"	Blank(空白): 压差式排水 Differential Pressure Drain S: 压差式和手动排水 Manual & Differential Pressure Drain D: 自动排水 Automatic Drain



技术参数 /Specification:

型号 /Type	F-02	UF-02	UF-03	UF-04	UF-06	UF-08
接管口径 /Port size (G)	1/4"	1/4"	3/8"	1/2"	3/4"	1"
工作介质 /Fluid	压缩空气 /Compressed Air					
使用压力范围 /Operating pressure range (MPa)	0.15-0.85					
最大处理流量 /Max. Flow rate (L/min)	1850	2050	2500	7900	8100	
使用温度范围 /Ambient temperature (°C)	-10-60					
过滤精度 /Filter precision	标准 /Standard: 20 μ m					
杯子材质 /Cup material	聚碳酸酯 /Polycarbonate					
防护罩 /Guard cup	-	●	●	●	●	●

■ F-02

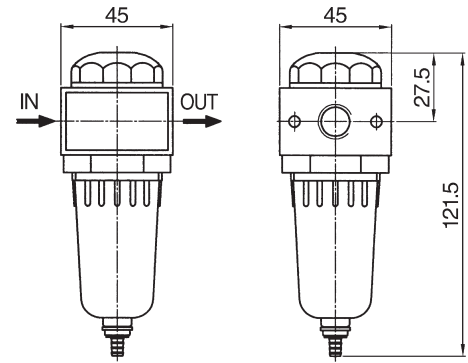

外形尺寸 /Dimension(mm):

■ UF-02,03,04

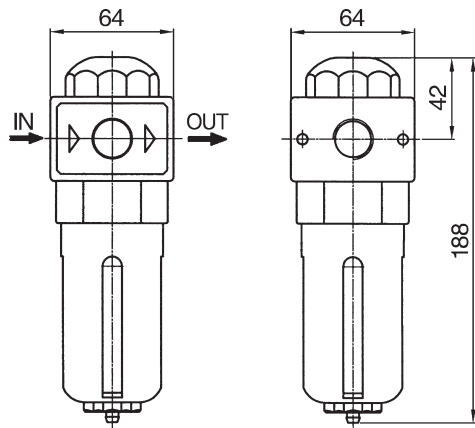

■ UF-06,08

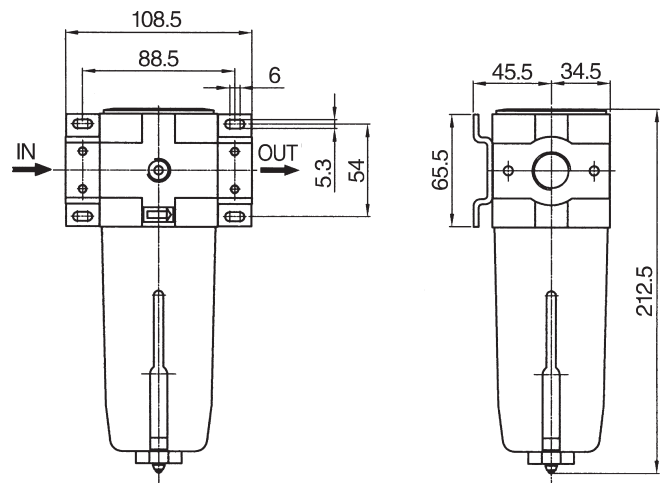

空气处理设备