

过滤调压器 + 油雾器 /Filter Regulator+Lubricator

型号注释 /Note for type:

UFR/L	—	02	D
↓		↓	↓
系列代码: Series Code:		接管口径: Joint Pipe Bore:	排水方式: Drian Type:
FR/L、UFR/L 系列二联件 FR/L、UFR/L Series FR.L Combination		02:G1/4" 03:G3/8" 04:G1/2" 06:G3/4" 08:G1"	Blank(空白):压差式排水 Differential Pressure Drain S:压差式和手动排水 Manual & Differential Pressure Drain D:自动排水 Automatic Drain

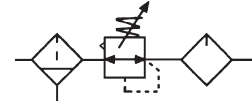

技术参数 /Specification:

型号 /Type	FR/L-02	UFR/L-02	UFR/L-03	UFR/L-04	UFR/L-06	UFR/L-08
接管口径 /Port size (G)	1/4"	1/4"	3/8"	1/2"	3/4"	1"
压力表接管口径 /Gauge thread (G)	1/8"	1/4"				
工作介质 /Fluid	压缩空气 /Compressed Air					
使用压力范围 /Operating pressure range (MPa)	0.15~0.85					
最大处理流量 /Max.Flow rate(L/min)	1850	2050	2500	7900	8100	
使用温度范围 /Ambient temperature(°C)	-10~60					
过滤精度 /Filter precision	标准 /Standard: 20 μ m					
推荐使用油 /Oil recommended	ISO VG32					
杯子材质 /Cup material	聚碳酸酯 /Polycarbonate					
构造 /减压阀 /Structure	活塞型 /Piston type					
防护罩 /Guard cup	- / ●	●	●	●	●	●

外形尺寸 /Dimension(mm):

■ FR/L-02

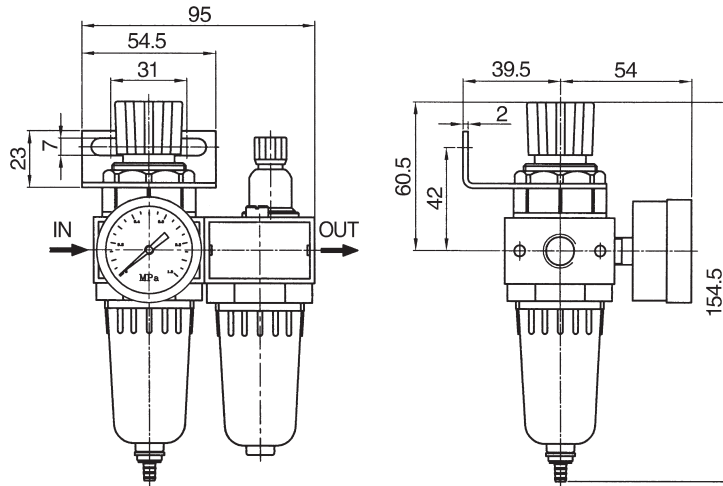

■ UFR/L-02,03,04

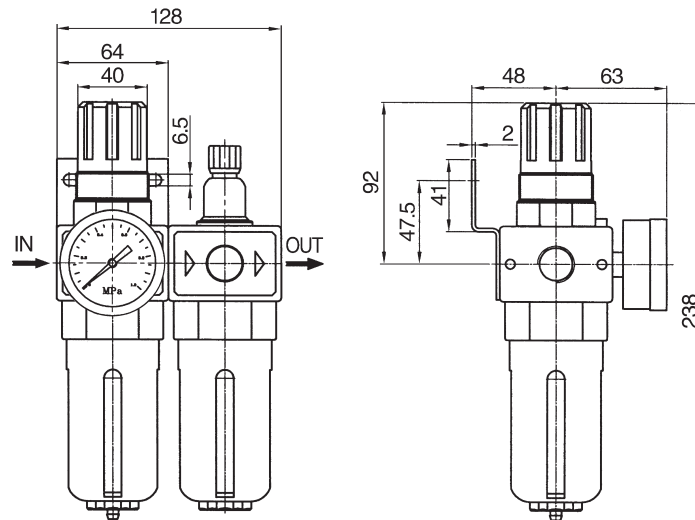

■ UFR/L-06,08

