

过滤调压器 /Filter Regulator

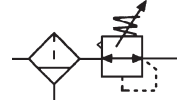

型号注释 /Note for type:

DFR	200	01	D
系列代码: Series Code:	型式: Type:	接管口径: Joint Pipe Bore:	排水方式: Drian Type:
DFR 系列过滤调压器 DFR Series Filter Regulator	100 200 400 600	M5, 01:G1/8" 02:G1/4" 03:G3/8" 04:G1/2" 06:G3/4" 08:G1"	Blank(空白):压差式排水 Differential Drain D:自动排水 Automatic Drain



技术参数 /Specification:

型号 /Type	DFR100-M5,01	DFR200-01, 02, 03	DFR400-03, 04, 06	DFR600-06, 08
接管口径/Port size (G)	M5 · 1/8"	1/8" · 1/4" · 3/8"	3/8" · 1/2" · 3/4"	3/4" · 1"
压力表接管口径 /Gauge thread (G)	M5	1/8"	1/4"	
工作介质 /Fluid	压缩空气 /Compressed Air			
使用压力范围/Operating pressure range (MPa)	0.15-0.85	0.15-1.2		
最大处理流量/Max.Flow rate(L/min)	500	1700	3500	11500
使用温度范围/Ambient temperature(°C)	-10-60			
过滤精度 /Filter precision	标准 /Standard: 40 μ m			
杯子材质/Cup material	聚碳酸酯 /Polycarbonate			
防护罩 /Guard cup	-	●	●	●

外形尺寸 / Dimension(mm):

■ DFR100-M5、01

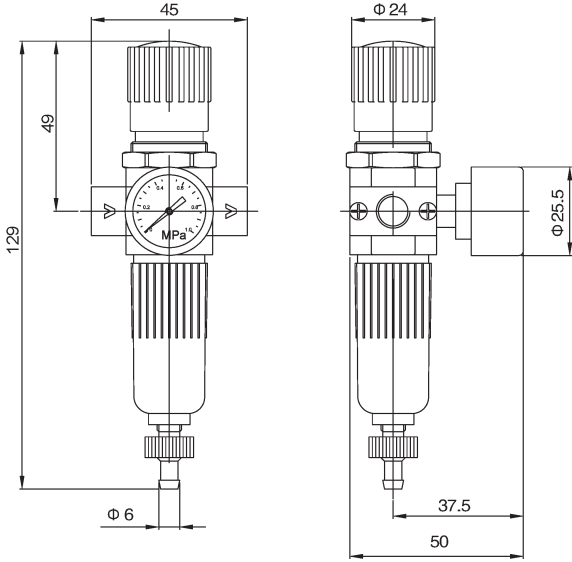

■ DFR200-01、02、03

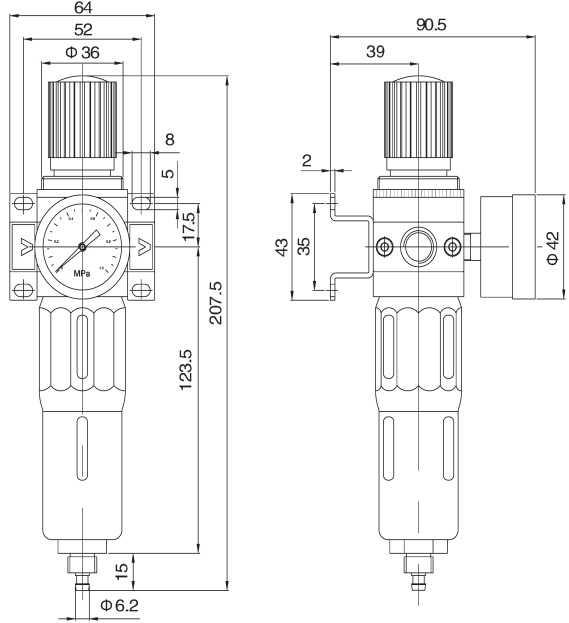

■ DFR400-03、04、06

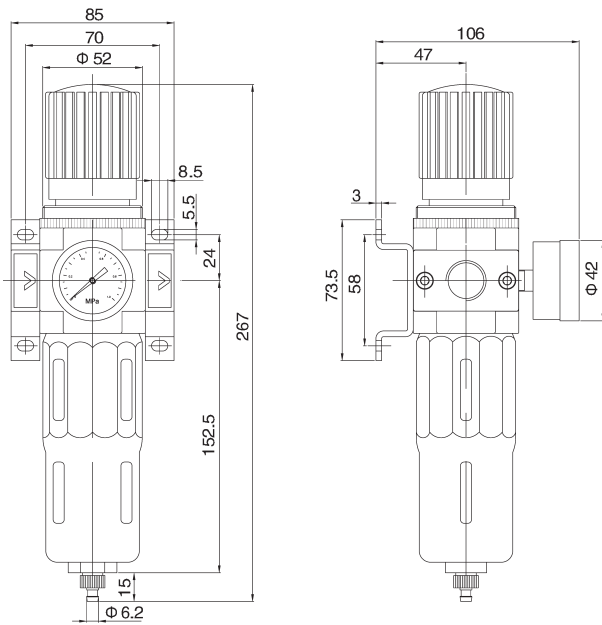

■ DFR600-06、08

