

## 过滤调压器 + 油雾器 /Filter Regulator+Lubricator

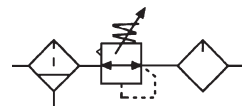

## 型号注释 /Note for type:

<b>DC</b>	<b>201</b>	<b>01</b>	<b>D</b>
系列代码: Series Code:	型式: Type:	接管口径: Joint Pipe Bore:	排水方式: Drain Type:
DC 系列二联件 DC Series	101 201	M5, 01:G1/8"	Blank(空白):压差式排水 Differential Drain
FR.L Combination	401 601	02:G1/4" 03:G3/8" 04:G1/2" 06:G3/4" 08:G1"	D:自动排水 Automatic Drain



## 技术参数 /Specification:

型号 /Type	DC101-M5、01	DC201-01、02、03	DC401-03、04、06	DC601-06、08
接管口径/Port size (G)	M5 · 1/8"	1/8" · 1/4" · 3/8"	3/8" · 1/2" · 3/4"	3/4" · 1"
压力表接管口径 /Gauge thread (G)	M5	1/8"	1/4"	
工作介质 /Fluid	压缩空气 /Compressed Air			
使用压力范围/Operating pressure range (MPa)	0.15-0.85	0.15-1.2		
最大处理流量/Max.Flow rate(L/min)	500	1700	3500	11500
使用温度范围/Ambient temperature(°C)	-10-60			
过滤精度 /Filter precision	标准 /Standard: 40 μ m			
杯子材质/Cup material	聚碳酸酯 /Polycarbonate			
防护罩 /Guard cup	-	●	●	●

空气处理设备

## 内部结构图 /Inner structure drawing:

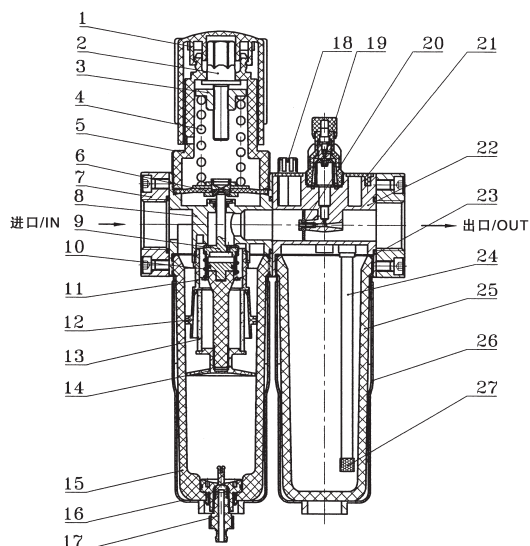

序号 /No	名称 /Code	序号 /No	名称 /Code
1	主调压钮 /Adjustable button	15	水杯 /Water cup
2	调压轴 /Adjustable launch	16	护罩 /Guard cup
3	调压螺母 /Nut	17	排水器 /Drainer
4	主调压弹簧 /Main adjustable spring	18	堵头 /Plug
5	阀盖 /Valve cover	19	油窗组件 /Oil window components
6	调压膜片 /Diaphragm	20	阻尼片 /Damping fin
7	连接块 /Connecting block	21	装饰盖 /Decorative cover
8	过滤阀体 /Filter body	22	油雾阀体 /Lubricator valve body
9	阀芯 /Regulator core	23	O型圈 /O-ring
10	阀芯弹簧 /Regulator core spring	24	油管 /Oil tube
11	阀芯座 /Core pedestal	25	油杯 /Oil cup
12	旋风叶片 /Impeller	26	护罩 /Oil cup block
13	滤芯 /Cartridge	27	滤芯 /Filter core
14	挡板 /Barrier board		

外形尺寸 / Dimension(mm):

■ DC101-M5、01

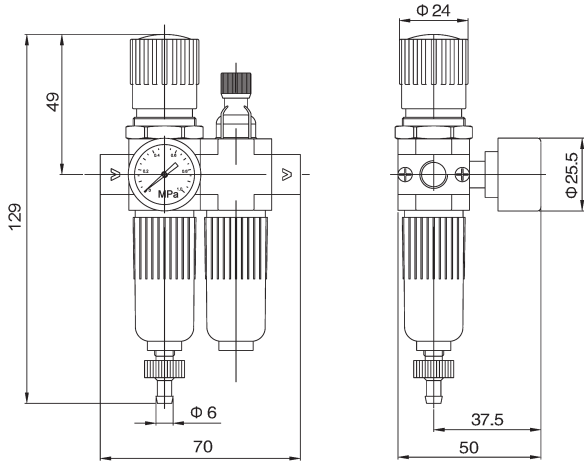

■ DC201-01、02、03

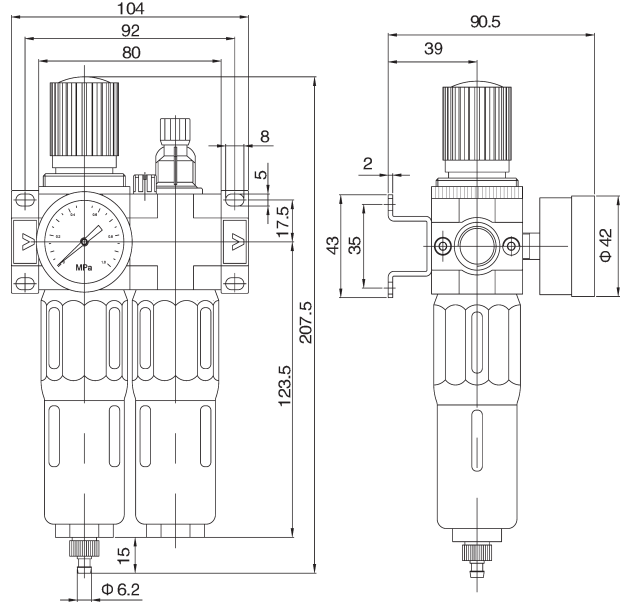

■ DC401-03、04、06

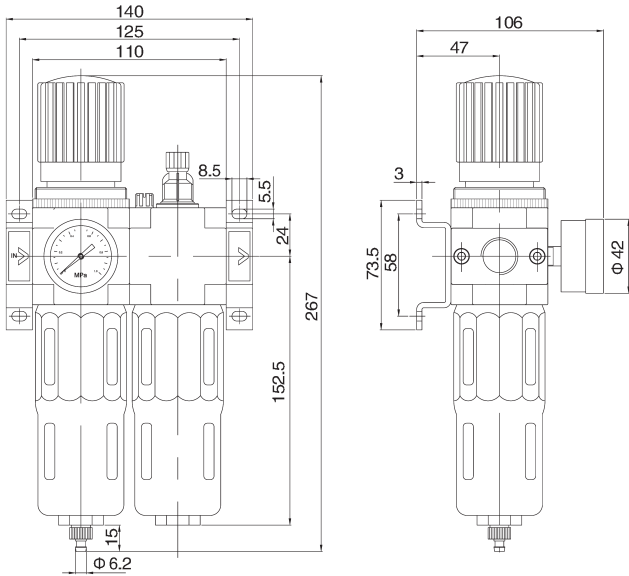

■ DC601-06、08

